

S5990FZ6 & S5990FZ3

60CM FULLY INTEGRATED SERIES COLUMN FREEZER, 359L CAPACITY







- 
MADE IN ITALY
- 
60CM SIZE
- 
359L CAPACITY
- 
EVENLIFT ADJUSTABLE SHELVES
- 
DUAL MOVEMENT DOOR HINGE (PIVOT STYLE)
- 
FROST FREE
- 
TOUCH CONTROL
- 
SOFT CLOSE DRAWERS
- 
PROVENT
- 
OPTI-VIEW LED LIGHTS
- 
ANTIBACTERIAL STAINLESS STEEL INTERIOR
- 
ALL FREEZER
- 
ANTI VIBRATION
- 
VACATION MODE
- 
AVAILABLE WITH LEFT OR RIGHT HINGE
- 
5 YEAR WARRANTY

AN EXPRESSION OF QUALITY AND THE PINNACLE OF FOOD STORAGE

Fhiaba's integrated column freezer solution delivers dynamic food storage with easily adjustable shelving, high-performance compressor and antimicrobial stainless steel. The Provent air circulation technology consists of independent ventilation for each compartment and provides uniform and precise temperature control, ensuring better food preservation.

Pair perfectly with any of Fhiaba's refrigerators or wine cellars for the ultimate culinary cold storage and wine preservation system for your home. Fhiaba integrated refrigerator or freezer are designed to be fitted with a custom door panel and handle to match your kitchen and blend into the aesthetic of your kitchen space for a seamless installation. The design solutions are only limited to your imagination and design.

Exclusive Fhiaba technology makes it possible to combine the four "key variables" of refrigeration, to create and maintain perfectly balanced climates.

-  **Accurate temperatures**
Thanks to the numerous built-in sensors, the indicated temperature is always accurate.
-  **Uniform ProVent Ventilation**
The ProVent system uniformly distributes cold air to all parts of the fridge.
-  **TriPro Refrigeration**
The triple cooling system ensures each ingredient and dish gets the right micro-climate.
-  **Humidity control**
Our wine cellars offer three different humidity level settings: low, medium and high.



Pictured: S5990FZ3 with left hand hinge

S5990FZ6 & S5990FZ3

60CM FULLY INTEGRATED SERIES COLUMN FREEZER, 359L CAPACITY



PRODUCT DETAIL

FEATURES

- Meticulously designed & built to withstand prolonged use
- Available with left or right hand hinge
- Integrated design to seamlessly blend into your kitchen
- Large all freezer removes the need for secondary food storage solutions meaning all your frozen food can be preserved in one convenient location
- Ideal large capacity for your frozen foods and accommodating complete design flexibility within your kitchen, this column freezer will pair perfectly with Fhiaba's other integrated units.
- Total No Frost - 100% automatic system which eliminates the need to defrost the fridge, fresh food and freezer compartments. In addition it enables the temperature to be restored quickly after opening thanks to 'speed freezing'.
- Smart-touch TFT controls manages and monitors the entire fridge operation process is simple to use. Fridge, fresh food compartment and drawer temperatures are shown on the digital display
- Independent ventilation for each storage compartment, resulting in uniform and precise temperature control, and ensuring optimum food preservation.
- Accurate temperatures. Thanks to the built-in thermostat, the temperature is always accurate
- Insulated variable speed compressor maintains precision temperature control with minimal vibration
- Provent creates an 'air curtain' to prevent cold air from escaping when the door opens. Provent: also guarantees a homogeneous distribution of cold air and favours the deep use of the internal compartments.
- Uniform temperature throughout allowing for better food preservation conditions
- Fhiaba Link Device (FLD) optional
- Deep capacity within a standard depth is achieved by a side-mounted evaporator, which leaves greater interior space
- EvenLift™ means shelves can slide up and down to be adjusted to any height in the fridge compartment
- Air purification system
- Insulated dual variable speed compressor assists in maintaining a precise temperature control with anti-vibration.
- Low vibration compressor

- Three independent electronically controlled cooling zones for maximum flexibility:
- Antimicrobial EverCrisp™ drawers prevent growth of micro-organisms and cross-contamination with bead-blasted stainless steel.

INTERIOR

- Complete anti-bacterial stainless steel interior including shelves and side panels
- Soft-close doors and drawers in all compartments
- 2 tempered glass shelves with aluminium profiles
- 4 Micro shot-peened stainless steel drawers
- Full extraction drawers with soft closing runners
- Hygienic rounded corner drawers for easy cleaning
- 2 door shelves fully adjustable in height
- 5 LED lights illuminate the fridge from the side & 2 LED lights at the top and side interior provide excellent visibility without creating annoying hot spots

TEMPERATURE

- Freezer: from -15°C to -22 °C

DOOR

- Dual-movement patented hinge, with self-balancing movement ensures stability and resistance
- Pivoting door hinge system enables the appliance to be built-in
- Door open alarm
- Door opening angle: 105°

NOISE

- Noise level - 41db

CAPACITY

- Freezer Use-able Storage Capacity:359L

TECHNICAL

- Uniform 2050mm height across all Integrated models
- Energy consumption: 408kw/yr
- Net Weight: 180kg
- Power lead length: 2m
- Front and rear adjustable feet up to 25mm height

ACCESSORIES

- KCCIT Joining kit - central (Joining brackets, airflow separation included)
- AISI 304 Vertical tubular door handle, round section Ø30 mm x 1104 mm long
- KITNRG599 - Transformer for network integration with alternative energy (photovoltaic and geothermal energy, home automation, etc.)

FOLLOW US ON:



/fhiaba_refrigerationau/

fhiaba.com.au

P: 1300 694 583

Eurolinx Showrooms are open Tuesday - Friday 9am - 5pm, Saturday - 10am - 4pm, Sunday and Monday - closed*

***Perth: Tuesday - Friday 10am - 4pm, Saturday, Sunday and Monday - closed**

NEW SOUTH WALES (Head Office)

48-50 Moore Street
Leichhardt

VICTORIA

2r/131 Church St,
Hawthorn

QUEENSLAND

1/42 Cavendish Road
Coorparoo

WESTERN AUSTRALIA

Unit 10/55 Howe Street
Osborne Park

Page 2/5
03052022

DISCLAIMER

Eurolinx PTY LTD, is continually seeking ways to improve the design specifications, aesthetics and production techniques of its products. As a result alterations to our products and designs take place continually. Whilst every effort is made to produce information and literature that is up to date, this brochure should not be regarded as an infallible guide to the current specifications, nor does it constitute an offer for the sale of any particular product. Product dimensions indicated in our literature is indicative only. Actual product only should be used to define dimension cut outs. Distributors, and retailers are not agents of Fhiaba and are not authorised to bind Fhiaba by any express or implied undertaking or representation.

S5990FZ6 & S5990FZ3

60CM FULLY INTEGRATED SERIES COLUMN FREEZER, 359L CAPACITY

PRODUCT SPECIFICATIONS AND DIMENSIONS

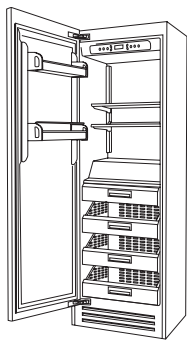
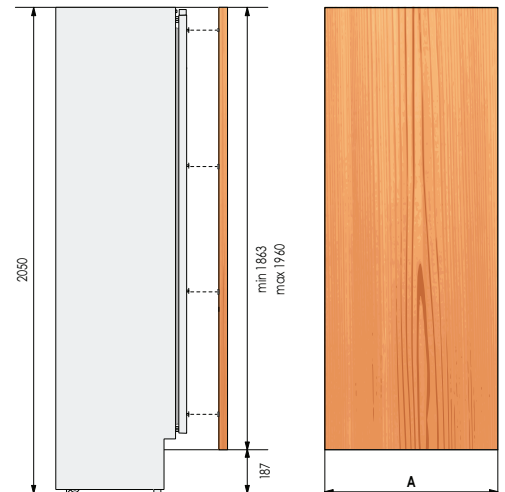
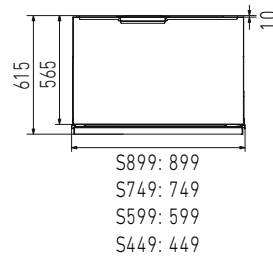
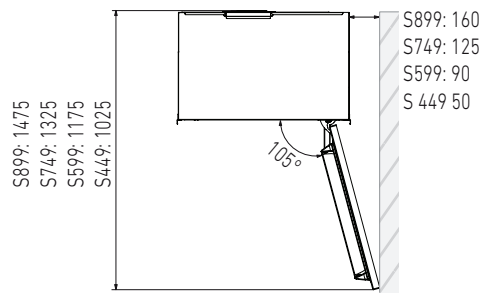
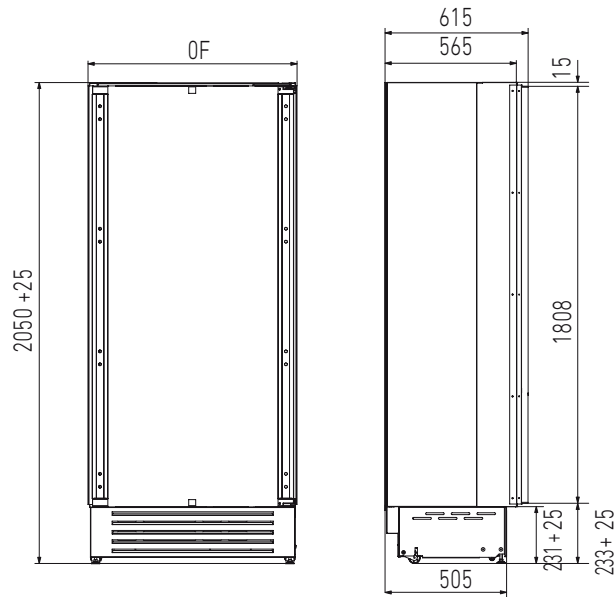
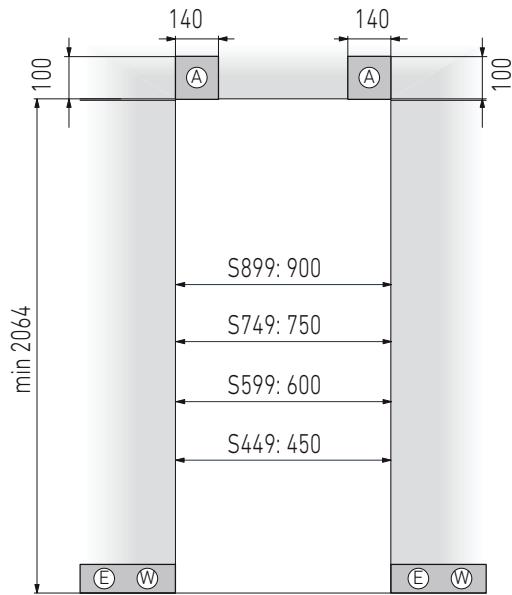

Integrated S5990FZ Panel Recommendations

Panels with a width ranging between 18mm and 28mm. Door panels with a maximum weight of 23kgs and drawer panels with a maximum weight of 11kgs.



For installation specifications, please consult with Fhiaba. For optimum installation, we recommend using the actual product as the best guide.

Series	Door / Drawer Width A	Door / Drawer Width B
599	597	327

FOLLOW US ON:



/fhiaba_refrigerationau/

fhiaba.com.au

P: 1300 694 583

Eurolinx Showrooms are open Tuesday - Friday 9am - 5pm, Saturday - 10am - 4pm, Sunday and Monday - closed*

***Perth: Tuesday - Friday 10am - 4pm, Saturday, Sunday and Monday - closed**

NEW SOUTH WALES
(Head Office)

48-50 Moore Street
Leichhardt

VICTORIA

2r/131 Church St,
Hawthorn

QUEENSLAND

1/42 Cavendish Road
Coorparoo

WESTERN AUSTRALIA

Unit 10/55 Howe Street
Osborne Park

Page 3/5
03052022

DISCLAIMER

Eurolinx PTY LTD, is continually seeking ways to improve the design specifications, aesthetics and production techniques of its products. As a result alterations to our products and designs take place continually. Whilst every effort is made to produce information and literature that is up to date, this brochure should not be regarded as an infallible guide to the current specifications, nor does it constitute an offer for the sale of any particular product. Product dimensions indicated in our literature is indicative only. Actual product only should be used to define dimension cut outs. Distributors, and retailers are not agents of Fhiaba and are not authorised to bind Fhiaba by any express or implied undertaking or representation.

S5990FZ6 & S5990FZ3

60CM FULLY INTEGRATED SERIES COLUMN FREEZER, 359L CAPACITY

PRODUCT SPECIFICATIONS AND DIMENSIONS



Side by side installation

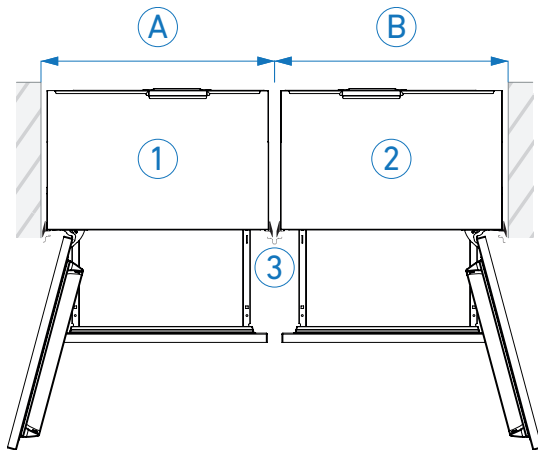

- 1 - Device 1
- 2 - Device 2
- 3 - Joining kit
- A - Niche device 1
- B - Niche device 2

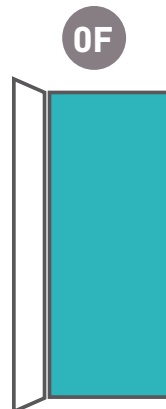
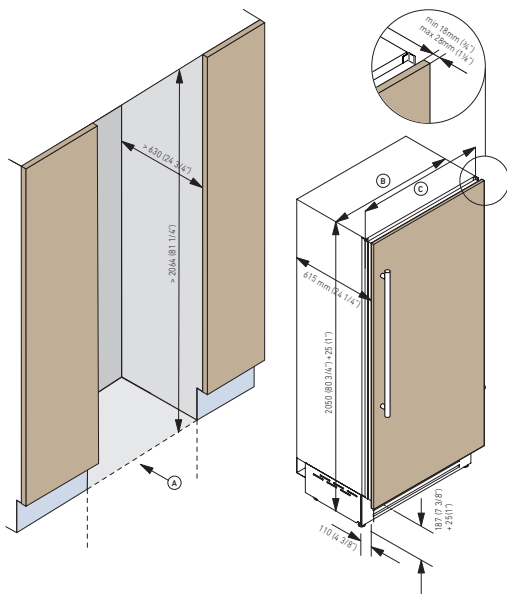

1D | 1M
freezer
D = door
M = separate microclimates

TECHNICAL DATA	
Niche Width A (mm)	600
Unit Width B (mm)	587
Unit Width with lateral frames C (mm)	599

For installation specifications, please consult with Fhiaba. For optimum installation, we recommend using the actual product as the best guide.

FOLLOW US ON:

/fhiaba_refrigerationau/

fhiaba.com.au

P: 1300 694 583

Eurolinx Showrooms are open Tuesday - Friday 9am - 5pm, Saturday - 10am - 4pm, Sunday and Monday - closed*

***Perth: Tuesday - Friday 10am - 4pm, Saturday, Sunday and Monday - closed**

NEW SOUTH WALES
(Head Office)

48-50 Moore Street
Leichhardt

VICTORIA

2r/131 Church St,
Hawthorn

QUEENSLAND

1/42 Cavendish Road
Coorparoo

WESTERN AUSTRALIA

Unit 10/55 Howe Street
Osborne Park

Page 4/5
03052022

DISCLAIMER

Eurolinx PTY LTD, is continually seeking ways to improve the design specifications, aesthetics and production techniques of its products. As a result alterations to our products and designs take place continually. Whilst every effort is made to produce information and literature that is up to date, this brochure should not be regarded as an infallible guide to the current specifications, nor does it constitute an offer for the sale of any particular product. Product dimensions indicated in our literature is indicative only. Actual product only should be used to define dimension cut outs. Distributors, and retailers are not agents of Fhiaba and are not authorised to bind Fhiaba by any express or implied undertaking or representation.

S5990FZ6 & S5990FZ3

60CM FULLY INTEGRATED SERIES COLUMN FREEZER, 359L CAPACITY

INSTALLATION INFORMATION



Flush installation

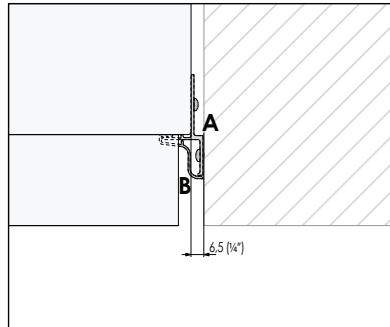
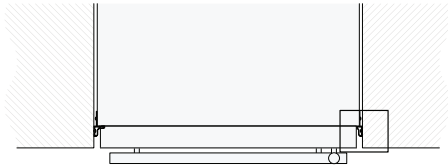

The Lateral Connection Kit (KCLIT/KCLIH/KCLMT/KCLMH) is supplied on all models (except in the unit with stainless steel sides) and consists of a connection element (A) and a aluminium frame (B).

Prominent installation

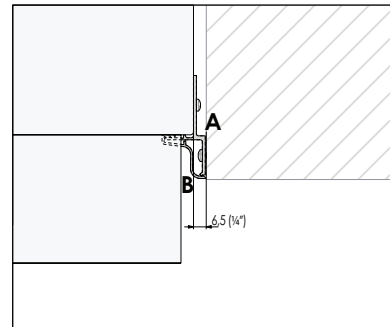
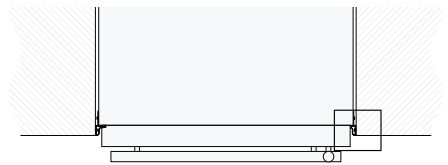

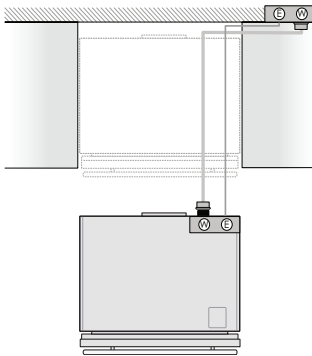

The Lateral Connection Kit (KCLIT/KCLIH/KCLMT/KCLMH) is supplied on all models (except in the unit with stainless steel sides) and consists of a connection element (A) and a aluminium frame (B).

Electrical and Water connection

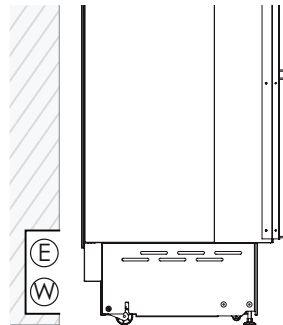

Electrical and Water connection behind the unit



 For installation specifications, please consult with Fhiaba. For optimum installation, we recommend using the actual product as the best guide.

FOLLOW US ON:

 /fhiaba_refrigerationau/

fhiaba.com.au

P: 1300 694 583
Eurolinx Showrooms are open Tuesday - Friday 9am - 5pm, Saturday - 10am - 4pm, Sunday and Monday - closed*
***Perth: Tuesday - Friday 10am - 4pm, Saturday, Sunday and Monday - closed**

NEW SOUTH WALES
(Head Office)
 48-50 Moore Street
 Leichhardt

VICTORIA
 2r/131 Church St,
 Hawthorn

QUEENSLAND
 1/42 Cavendish Road
 Coorparoo

WESTERN AUSTRALIA
 Unit 10/55 Howe Street
 Osborne Park

Page 5/5
 03052022

DISCLAIMER

Eurolinx PTY LTD, is continually seeking ways to improve the design specifications, aesthetics and production techniques of its products. As a result alterations to our products and designs take place continually. Whilst every effort is made to produce information and literature that is up to date, this brochure should not be regarded as an infallible guide to the current specifications, nor does it constitute an offer for the sale of any particular product. Product dimensions indicated in our literature is indicative only. Actual product only should be used to define dimension cut outs. Distributors, and retailers are not agents of Fhiaba and are not authorised to bind Fhiaba by any express or implied undertaking or representation.